

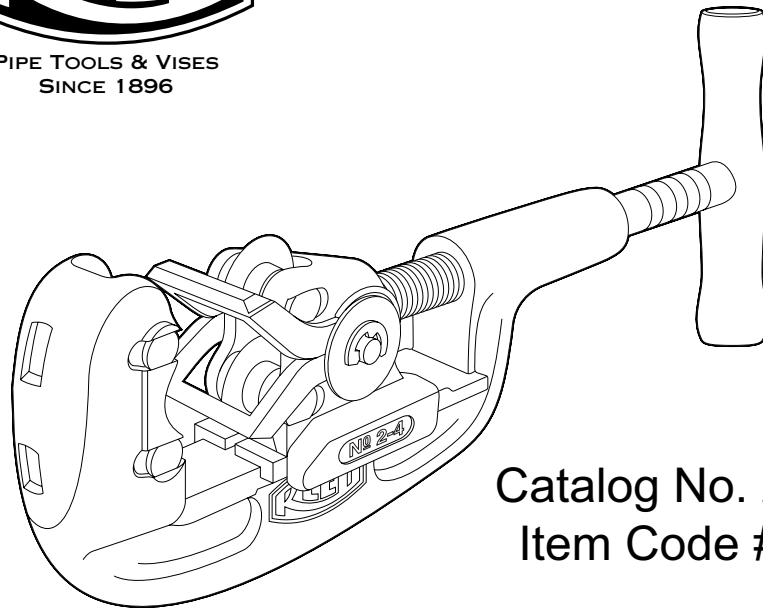

PIPE TOOLS & VISES  
SINCE 1896

## Pipe Cutter (with guides)

---



Catalog No. 2-4WG  
Item Code #03338

### Operating Instructions

1. Center the spring guide between the cutting wheels on the movable block. Open the cutter and slip over the pipe. Push the guide up against the pipe.
2. Line up the cutter wheels with your cut-off mark and turn the handle clockwise until the wheels penetrate the pipe approximately 1/64".
3. Rock the cutter back and forth far enough for the cutter wheels to overlap. You can proceed cutting off the pipe as fast as you like.
4. Cutting 1/2" pipe: After steps 1 and 2 above, rock the cutter back and forth far enough for the cutter wheels to overlap. Open the cutter and swing the guide out of the way so you can finish the cut without interference from the spring guide.

NOTE: After cutting off, it is recommended that the burr be removed by reaming the inside of the pipe. REED 2-71 Pipe Reamer (#06060) is made for this purpose (pipe capacity 1/8" - 2").

---

Reed Manufacturing Co.  
1425 West 8th St.  
Erie, PA 16502 USA  
Phone: 814-452-3691 or 800-666-3691  
Fax: 814-455-1697 or 800-456-1697

50028